

# AQUAmax<sup>®</sup> Basic - 5 EH Type P

N° 2015/06/125/A

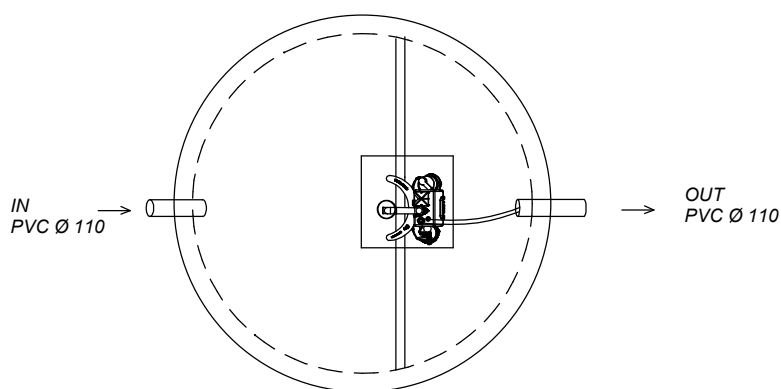

Capacité max : 05 EH  
Poids cuve : 6 670kg  
Matériau: Béton  
Conso elect.: 331 kWh/an  
Charge hydraul.max : 0,75 m3/jour

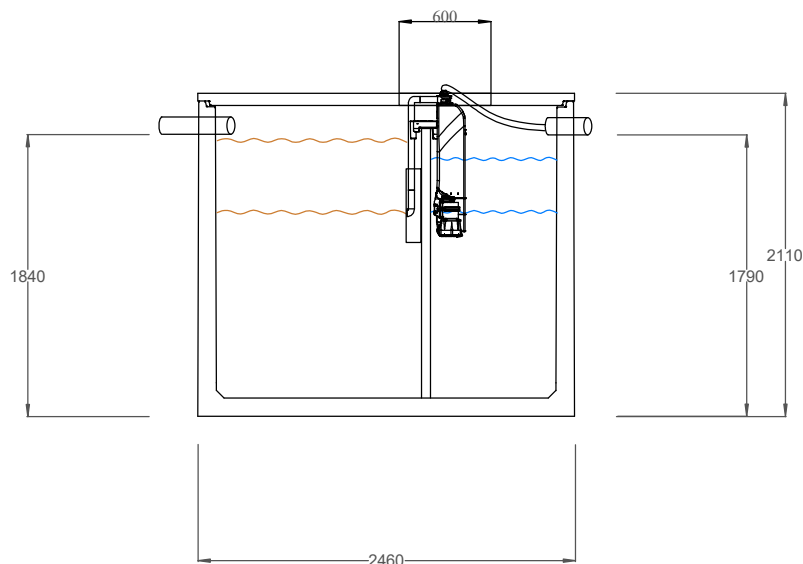

EN 12 566-3

**ATB Belgique SPRL**

Tel/Fax : 087 37 62 71  
info@atb-belgique.be  
www.atb-belgique.be

# AQUAmax<sup>®</sup> Basic - 5 EH

Type P renforcé

N° 2015/06/125/A

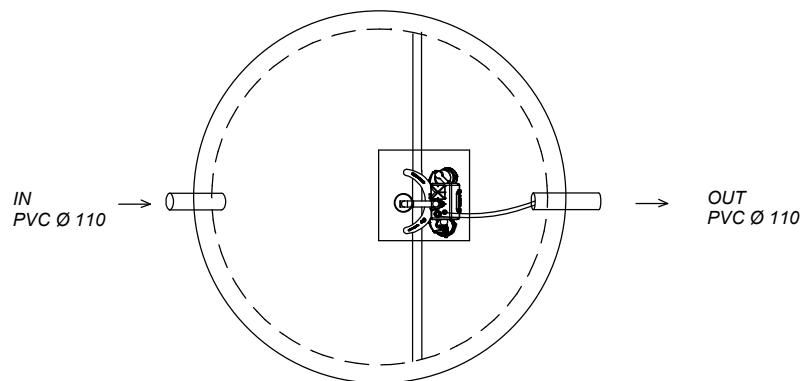
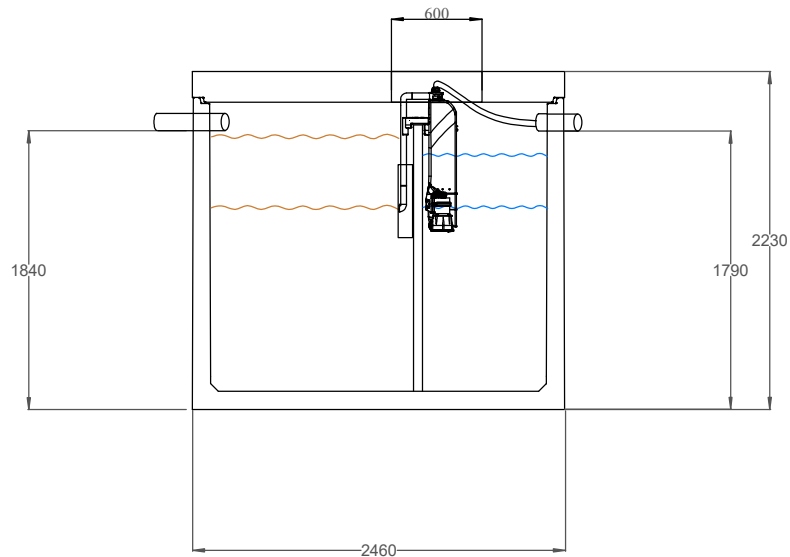

Capacité max : 05 EH  
Poids cuve : 8 070kg  
Matériau: Béton  
Conso elect.: 331 kW/an  
Charge hydraul.max : 0,75 m3/jour



EN 12 566-3

**ATB Belgique SPRL**

Tel/Fax : 087 37 62 71  
info@atb-belgique.be  
www.atb-belgique.be

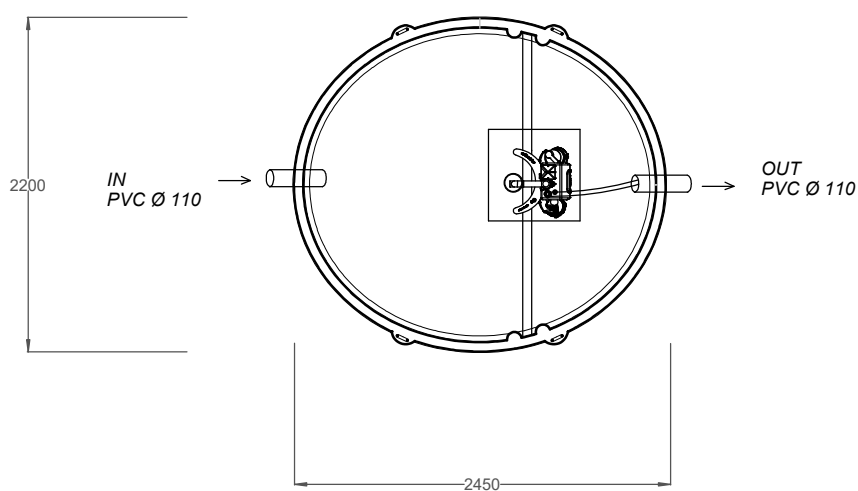
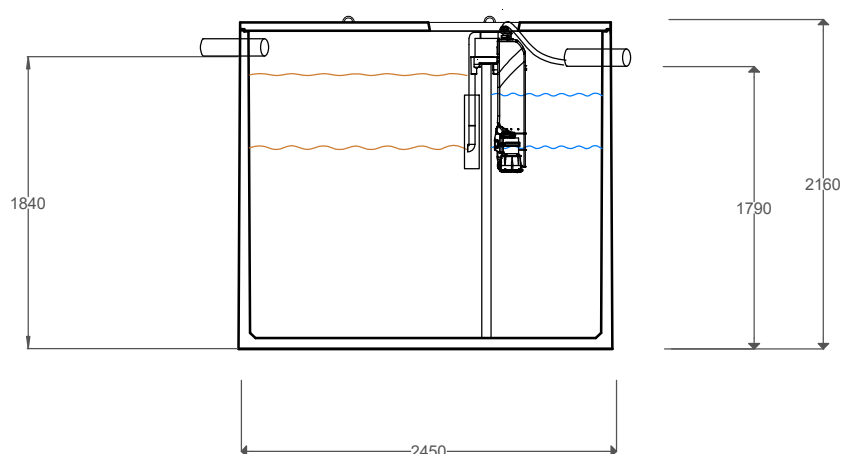

Capacité max : 05 EH  
Poids cuve : 4 250kg  
Matériau: Béton  
Conso elect.: 331 kW/an  
Charge hydraul.max : 0,75 m3/jour



EN 12 566-3

**ATB Belgique SPRL**

Tel/Fax : 087 37 62 71  
info@atb-belgique.be  
www.atb-belgique.be

# AQUAmax<sup>®</sup> Basic - 8 EH Type P

N° 2015/06/125/A

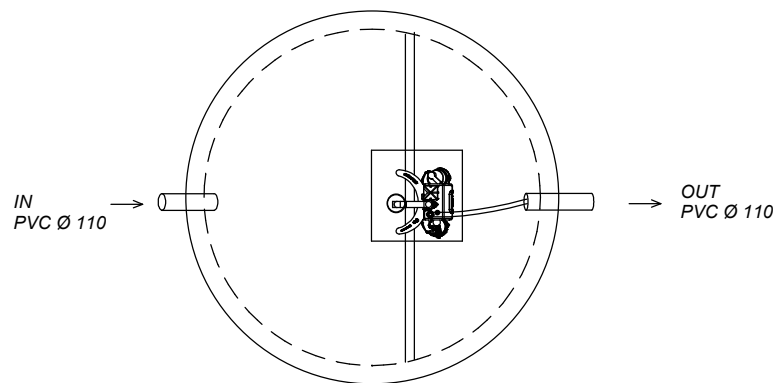
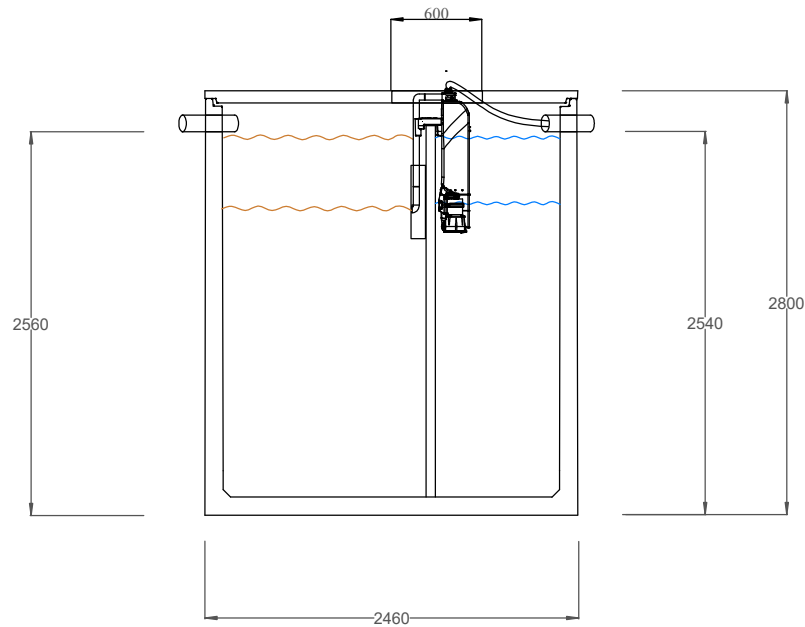

Capacité max : 08 EH  
Poids cuve : 8 160kg  
Matériau: Béton  
Conso elect.: 386 kWh/an  
Charge hydraul.max : 1,20 m3/jour



EN 12 566-3

**ATB Belgique SPRL**

Tel/Fax : 087 37 62 71  
info@atb-belgique.be  
www.atb-belgique.be

# AQUAmax<sup>®</sup> Basic - 8 EH

## Type P renforcé

N° 2015/06/125/A

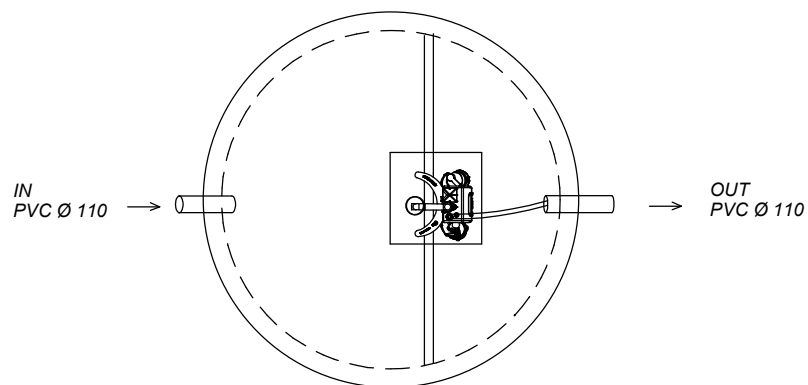
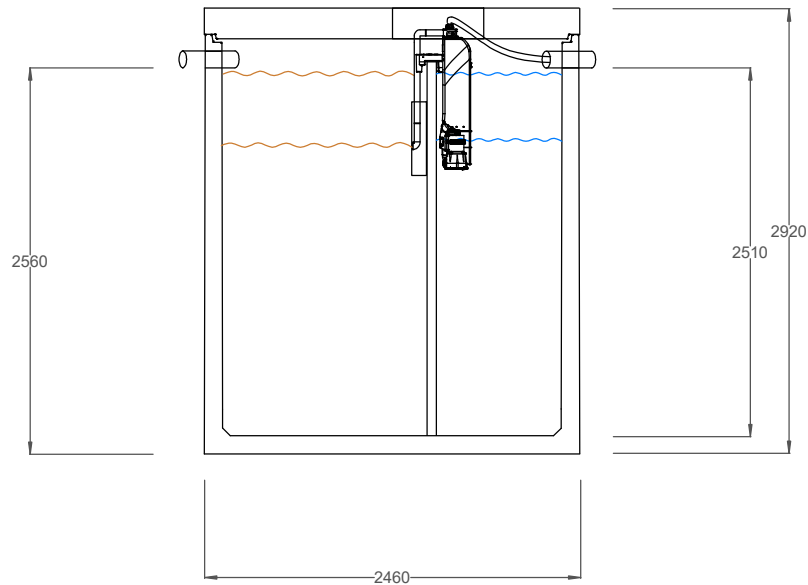

Capacité max : 08 EH  
Poids cuve : 9 550kg  
Matériau: Béton  
Conso elect.: 386 kWh/an  
Charge hydraul.max : 1,20 m3/jour



EN 12 566-3

## ATB Belgique SPRL

Tel/Fax : 087 37 62 71  
info@atb-belgique.be  
www.atb-belgique.be

# AQUAmax<sup>®</sup> Basic - 8 EH Type O

N° 2015/06/125/A

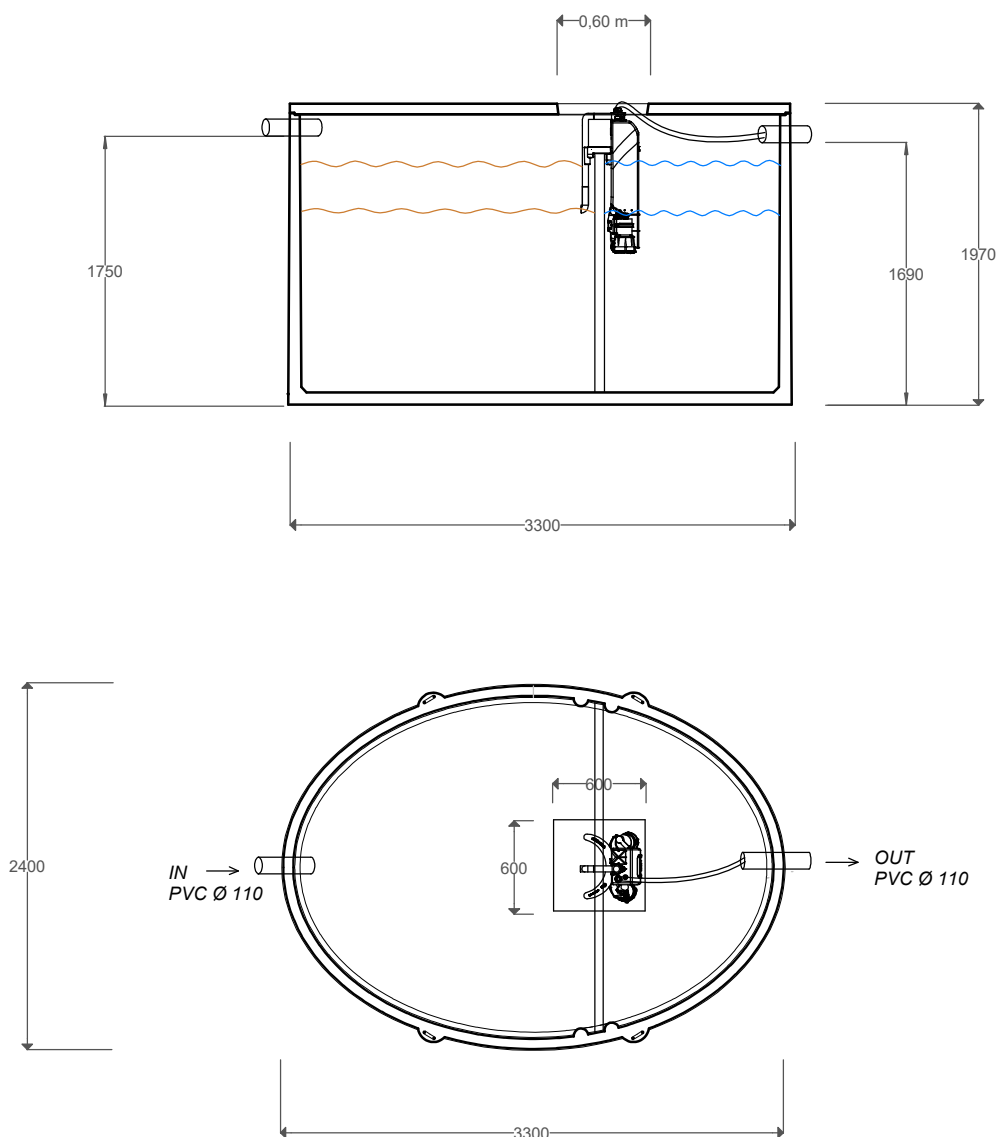

Capacité max : 08 EH  
Poids cuve : 5 800kg  
Matériau: Béton  
Conso elect.: 386 kWh/an  
Charge hydraul.max : 1,20 m3/jour



EN 12 566-3

**ATB Belgique SPRL**

Tel/Fax : 087 37 62 71  
info@atb-belgique.be  
www.atb-belgique.be

# AQUAmax<sup>®</sup> Basic - 10 EH Type P

N° 2015/06/125/A

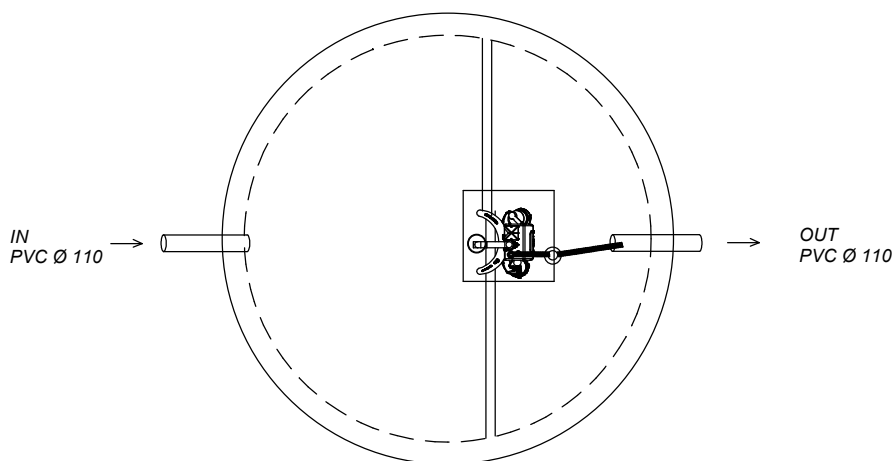
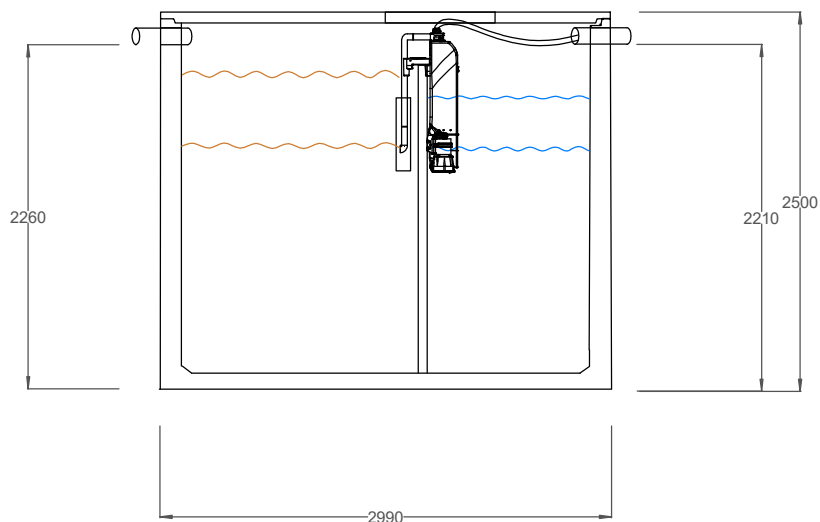

Capacité max : 10 EH  
Poids cuve : 9 350kg  
Matériau: Béton  
Conso elect.: 480 kWh/an  
Charge hydraul.max : 1,50 m3/jour



EN 12 566-3

**ATB Belgique SPRL**

Tel/Fax : 087 37 62 71  
info@atb-belgique.be  
www.atb-belgique.be

# AQUAmax<sup>®</sup> Basic - 10 EH

## Type P renforcé

N° 2015/06/125/A

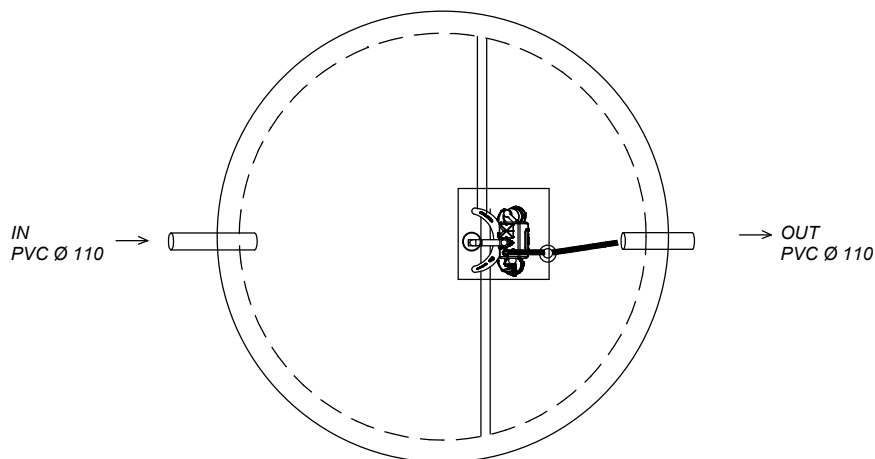
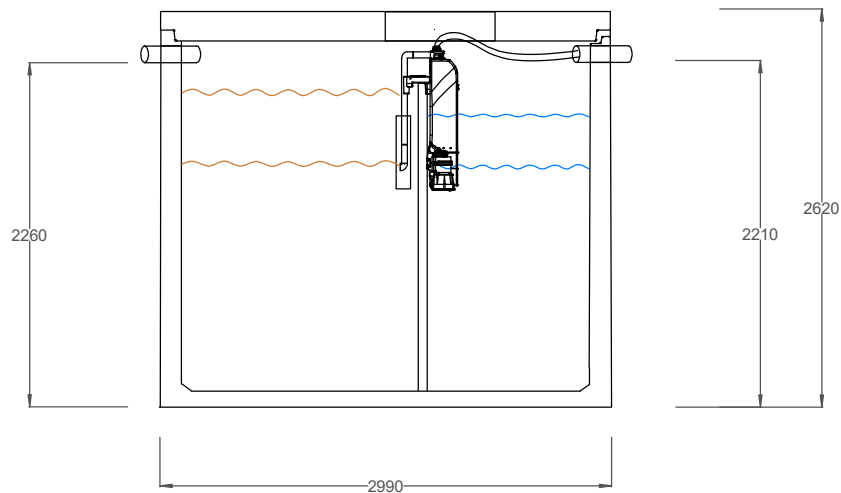

Capacité max : 10 EH  
Poids cuve : 11 450kg  
Matériau: Béton  
Conso elect.: 480 kWh/an  
Charge hydraul.max : 1,50 m3/jour



EN 12 566-3

## ATB Belgique SPRL

Tel/Fax : 087 37 62 71  
info@atb-belgique.be  
www.atb-belgique.be



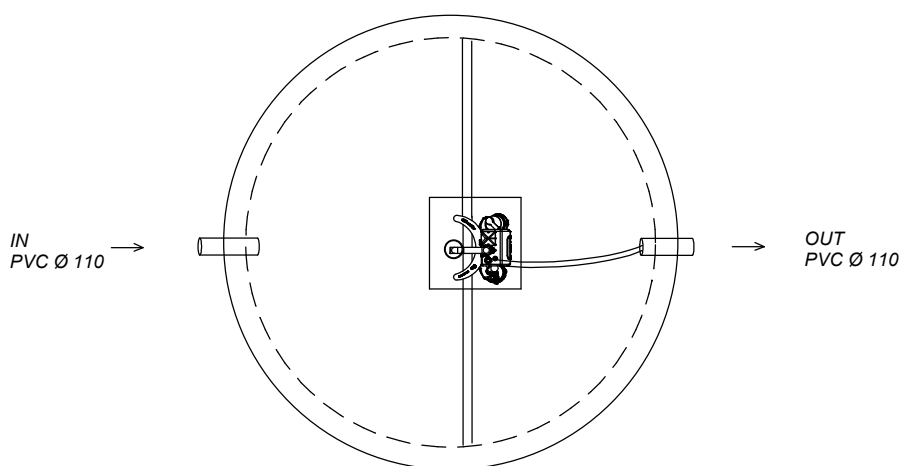
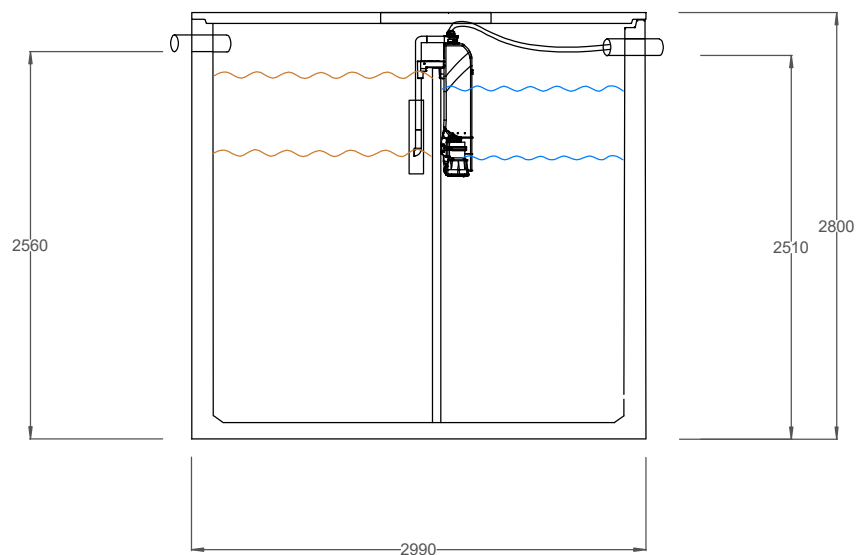

Capacité max : 16 EH  
Poids cuve : 10 500kg  
Matériau: Béton  
Conso elect.: 678 kWh/an  
Charge hydraul.max : 2,40 m3/jour



EN 12 566-3

**ATB Belgique SPRL**

Tel/Fax : 087 37 62 71  
info@atb-belgique.be  
www.atb-belgique.be

# AQUAmax<sup>®</sup> Basic - 16 EH

## Type P renforcé

N° 2015/06/125/A

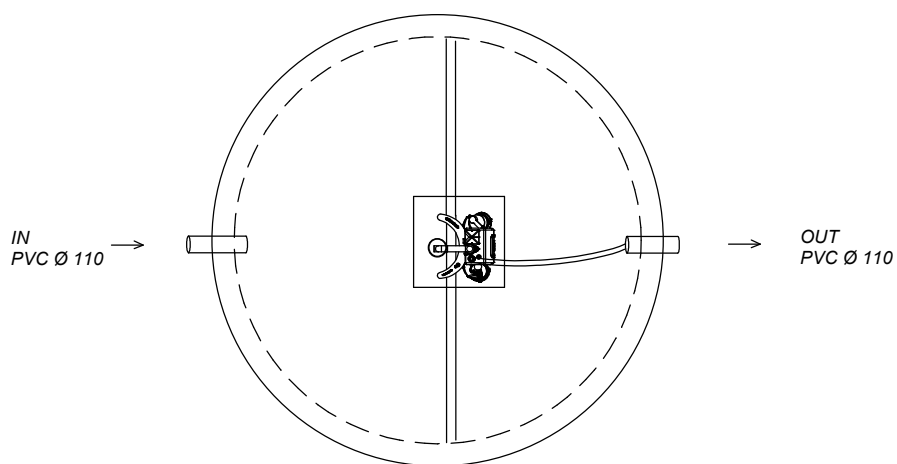
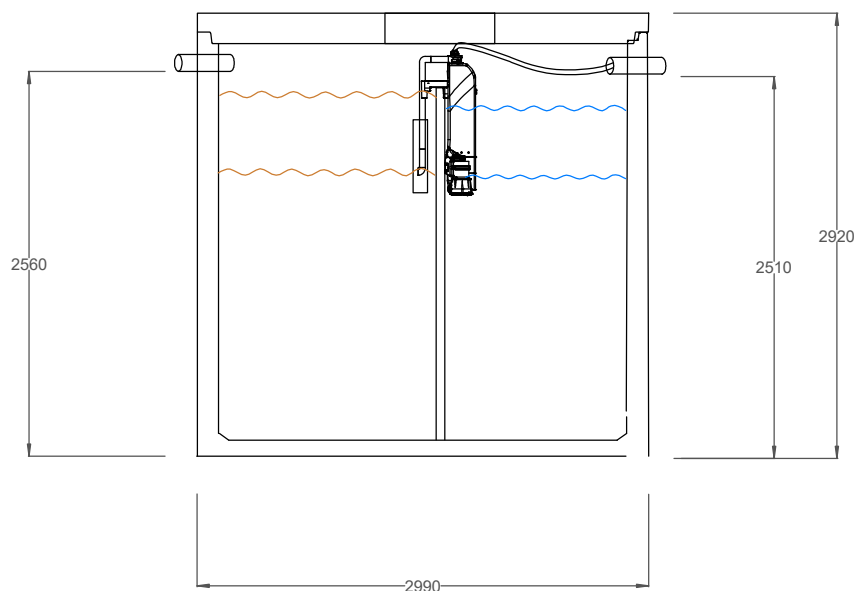

Capacité max : 16 EH  
Poids cuve : 12 550kg  
Matériau: Béton  
Conso elect.: 678 kWh/an  
Charge hydraul.max : 2,40 m3/jour



EN 12 566-3

## ATB Belgique SPRL

Tel/Fax : 087 37 62 71  
info@atb-belgique.be  
www.atb-belgique.be

# AQUAmax<sup>®</sup> Basic - 16 EH

## Type O

N° 2015/06/125/A

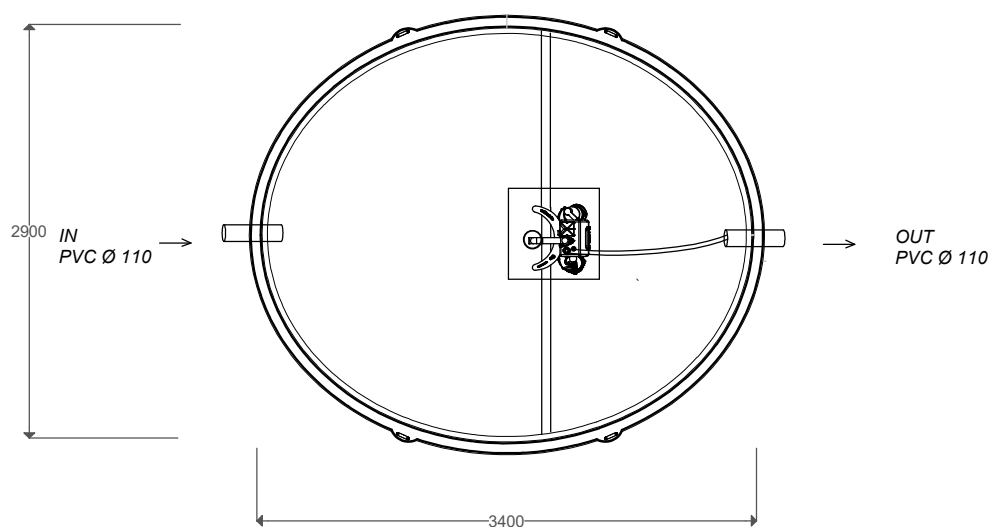
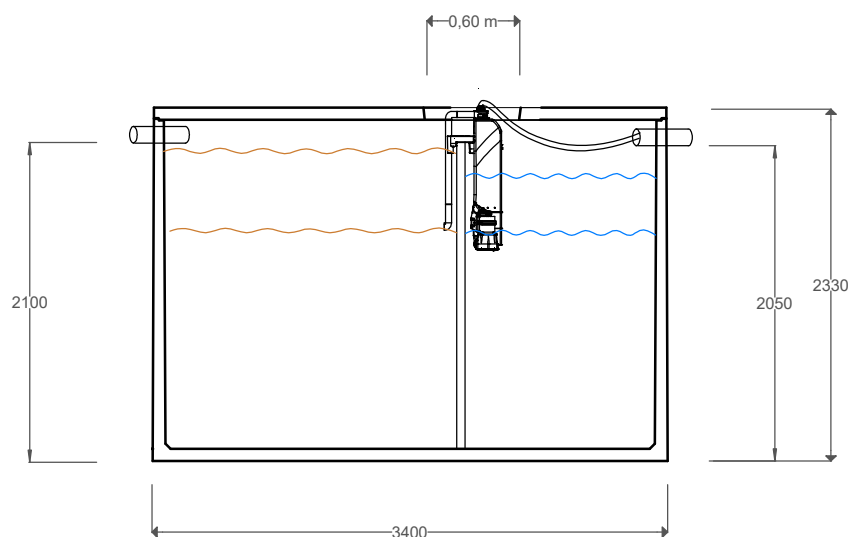

Capacité max : 16 EH  
Poids cuve : 7 400 kg  
Matériau: Béton  
Conso elect.: 678 kWh/an  
Charge hydraul.max : 2,40 m3/jour



EN 12 566-3

## ATB Belgique SPRL

Tel/Fax : 087 37 62 71  
info@atb-belgique.be  
www.atb-belgique.be